

# WACKER

## Operator's manual / Parts book

---

VPH 70

VPR 70

VPB 70

VPY 70



**FOREWORD**

For your own safety and protection from physical injury, carefully read, understand and observe the safety instructions.

Please operate and maintain your vibratory plate in accordance with the instructions in this instruction book. Your attention will be rewarded by trouble-free operation and high availability.

Defective machine parts are to be replaced as soon as possible. You will find the spare part you need and the relevant part number in the chapters "Spare parts" in this instruction book.



**VIBRATORS  
RAMMERS  
PLATES  
ROLLERS  
BREAKERS  
PUMPS**

(A.C.N. 004 650 580)

**MELBOURNE**  
913 Princes Highway  
Springvale, Vic. 3171  
Phone: (03) 8547 4033  
Fax: (03) 9562 3371

**ADELAIDE**  
501 Cross Keys Road  
Cavan S.A. 5084  
Phone: (08) 8262 8855  
Fax: (08) 8262 8866

**BRISBANE**  
Unit 2, 6-8 Pendrey Court  
Woodridge, Qld. 4114  
Phone: (07) 3208 6577  
Fax: (07) 3808 3280

**PERTH**  
Unit P, 66-73 Hector Street  
Osborne Park, W.A. 6017  
Phone: (08) 9445 2811  
Fax: (08) 9445 2361

**SYDNEY**  
14 Vore Street  
Auburn, N.S.W. 2144  
Phone: (02) 9748 0368  
Fax: (02) 9748 0774

---

**WACKER AUSTRALIA PTY. LTD.**

HAZARD IDENTIFICATION, RISK ASSESSMENT AND CONTROL

COMPANY: **WACKER AUSTRALIA PTY. LTD.**  
 PLANT/EQUIPMENT: **SINGLE DIRECTION VIBRATION PLATE**  
 PLANT/TASK DESCRIBED: **COMPACTION OF SOIL, ASPHALT AND PAVERS**

PAGE: 1 of 2

OPERATING SAFETY

Familiarity and proper training are required for the safe operation of equipment!  
 Equipment operated improperly or by untrained personnel can be dangerous! Read operating instructions and Safety Guidelines to familiarise yourself  
 with the location and proper use of all instruments and controls. WEAR APPROPRIATE PERSONAL PROTECTIVE EQUIPMENT AT ALL TIMES!

HAZARD IDENTIFICATION	RISK ASSESSMENT	PRACTICABILITY (It is practicable to remove or mitigate the hazard or risk?)		RISK CONTROL
		YES	NO - Why not?	
<b>INHERY/DIE TO- CONTACT WITH V-BELT DURING OPERATION</b>	HIGH RISK, WHEN OPERATING WITH- OUT V-BELT GUARD	✓		1. WARNING IN INSTRUCTION MANUAL 2. CLOSED V-BELT GUARD
PLANT TIPPING OVER, ROLLING OVER	LOW RISK		ENVIRONMENT IN WHICH MACHINE IS OPERATED CANNOT BE CONTROLLED BY THE SUPPLIER.	1. WARNING IN INSTRUCTION MANUAL
OPERATOR SLEEPING, TRIPPING, FALLING	LOW RISK		ENVIRONMENT IN WHICH MACHINE IS OPERATED CANNOT BE CONTROLLED BY THE SUPPLIER.	1. WARNING IN INSTRUCTION MANUAL
BURNS ON EXHAUST PROTECTION GUARD	MEDIUM RISK		ONLY EXPENSIVE & IMPRACTICAL ENCLOSURES COULD MITIGATE THE RISK.	1. IMPRINT ON GUARD 2. WARNING IN INSTRUCTION MANUAL 
MANUALLY LIFTING THE MACHINE	HIGH RISK	✓		1. LIFTING HANDLES PROVIDED ALLOW LIFTING BY THE SAME NUMBER OF PERSONS SHARING THE WEIGHT 2. LIFTING INSTRUCTIONS IN MANUAL. 3. LIFTING EYE C/W DECAL "CRANE HOOK" ENCOURAGES MECHANICAL LIFTING.
CONTACT WITH VIBRATING PARTS OF MACHINE	LOW RISK		IT IS NECESSARY FOR PARTS OF THE MACHINE TO VIBRATE STRONGLY TO FULFIL THE TASK DESCRIPTION.	WARNING IN INSTRUCTION MANUAL
INCORRECT STARTING OF MACHINE	LOW RISK		NO ENGINEERING SOLUTION POSSIBLE. VERY LOW RISK.	1. SEE OPERATING INSTRUCTION 2. P.P.E.

**HAZARD IDENTIFICATION, RISK ASSESSMENT AND CONTROL**

COMPANY: **WACKER AUSTRALIA PTY LTD**  
 PLANT/EQUIPMENT: **SINGLE DIRECTION VIBRATION PLATE**  
 PLANT/TASK DESCRIBED: **COMPACTION OF SOIL, ASPHALT AND PAVERS**

HAZARD IDENTIFICATION	RISK ASSESSMENT	PRACTICABILITY (It is practicable to remove or mitigate the hazard or risk?)		RISK CONTROL
		YES	NO - Why not?	
INJURY DUE TO: INCORRECT GUIDANCE OF MACHINE	LOW RISK		NO RISK IF MACHINE IS GUIDED CORRECTLY.	WARNING IN INSTRUCTION MANUAL
EXPLOSION OR FIRE	MEDIUM RISK		WHEN REFUELLING MACHINE, FLAMMABLE LIQUIDS ARE EXPOSED AND VAPOURS ARE PRESENT, WHICH CANNOT BE AVOIDED.	WARNING IN INSTRUCTION MANUAL
VIBRATION ON OPERATING HANDLE	LOW RISK	✓		1. SHOCK ABSORBING GUIDING HANDLE DESIGN 2. WARNING IN INSTRUCTION MANUAL
SHOECAPTE OR STEEPER H.L. HEALTH DUE TO: EXHAUST FUMES & FUEL VAPOURS	MEDIUM RISK		EXHAUST FUMES AND PETROL VAPOURS ARE UNA VOIDABLE	WARNING IN INSTRUCTION MANUAL
DUST			ENVIRONMENTAL CIRCUMSTANCES IN WHICH MACHINE IS OPERATED IS BEYOND THE CONTROL OF THE SUPPLIER	WARNING IN INSTRUCTION MANUAL
NOISE	MEDIUM RISK			1. WARNING IN INSTRUCTION MANUAL 2. DECAL: HEARING PROTECTION

### SAFETY INSTRUCTIONS FOR THE USE OF VIBRATORY PLATES WITH COMBUSTION ENGINES

#### General instructions

1. Vibratory plates may only be operated by persons who
  - \* are at least 18 years of age
  - \* are physically and mentally fit for this job
  - \* have been instructed in guiding vibratory plates and proved their ability for the job to the employer
  - \* may be expected to carry out the job they are charged with carefully.

The persons must be assigned the job of guiding vibratory plates by the employer

2. Vibratory plates may only be used for compaction jobs. Both the manufacturer's operating instructions and these safety instructions have to be observed.
3. The persons charged with the operation of vibratory plates have to be made familiar with the necessary safety measures relating to the machine. In case of extraordinary uses the employer shall give the necessary additional instructions.
4. It is possible that this vibratory plate exceeds the admissible sound level of 89 dB (A). According to the rules for the prevention of accidents regarding emission of noise, the employees have to wear ear protection if the sound level reaches 89 dB (A) or more.

#### Operation

1. When starting a gasoline engine with a starter crank make sure you have assumed a proper position with respect to the engine and that your hands are placed properly on the crank.
  - \***ATTENTION!** Turn hand crank vigorously until engine starts, as otherwise the crank could rebound.
2. The functioning of operating levers or elements is not to be influenced or rendered ineffective.
3. During operation the operator may not leave the control elements.
4. The operator has to stop the engine of the vibratory plate before going on breaks. The machine has to be placed such that it cannot turn over.
5. Stop engine before filling fuel tank. When refilling fuel tank, do not allow fuel to come into contact with the hot parts of the engine or spill onto the ground.
6. Do not smoke or handle open fire near this machine.
7. The tank lid must fit tightly. Shut off fuel cock, if available when stopping the engine. For long distance transports of machine operated by fuel or fuel - mixtures, the fuel tank has to be drained completely.
  - \***ATTENTION!** Leaking fuel tanks may cause explosions and must therefore be replaced immediately.
8. Do not operate the machine in areas where explosions may occur.
9. Make sure that sufficient fresh air is available when operating vibratory plates with combustion engines in enclosed areas, tunnels, pits and deep trenches.
10. During operation keep your hands, feet and clothes away from the moving parts of the vibration plate. Wear safety shoes, head protection and eye protection glasses in case of trench operation where falling sand stones may be ejected.
11. When working near the edges of breaks, pits, slopes, trenches and platforms, vibratory plates are to be operated such that there is no danger of their turning over or dropping in.
12. When travelling backwards the operator has to guide the vibration plate laterally by its guide handle so that he will not be squeezed between the handle and a possible obstacle. Special care is required when working on uneven ground or when compacting coarse material. Make sure of a firm stand when operating the machine under such conditions.

13. Vibratory plates are to be guided such that hand injuries caused by solid objects are avoided.
14. Vibratory plates have to be guided such that their stability is guaranteed.
15. Machines with integrated transport trolley may not be parked or stored on the trolley. This device has only been designed to transport the machine.

### Safety checks

1. Vibratory plates may only be operated with all safety devices installed.
2. Before starting operation, the operator has to check that all control and safety devices function properly.
3. In case of defects of the safety devices or other defects reducing the operational safety of the vibration plate, the supervisor has to be informed immediately.
4. In case of defects jeopardising the operational safety of the vibration plate, the machine has to be stopped immediately.

### Maintenance

1. Only use original spare parts. Modifications to this machine, including the adjustment of the maximum engine speed set by the manufacturer, are subject to the express approval of WACKER. In case of non-observance all liabilities shall be refused.
2. All drive units have to be switched off before carrying out maintenance jobs. Deviations from this are only allowed if the maintenance or jobs require a running engine.
3. When working on vibratory plates equipped with electric starter, disconnect battery before carrying out maintenance or repair jobs on the electric parts of the machine.
4. Remove pressure from hydraulic lines before working on them. Caution: take care when removing hydraulic lines, for the oil may be very hot (up. to 80° C). Precautions are to be taken to prevent oil from splashing into the operator's eyes.
5. As soon as maintenance and repair jobs have been completed all safety devices have to be reinstalled properly.

### Transport

1. During transport, loading and unloading of vibration plates by means of lifting devices, appropriate slinging means or hooks have to be used on the lifting points provided for this purpose on the vibratory plate.
2. The load-carrying capacity of the loading ramps has to be sufficient and the ramps have to be secure such that they cannot turn over. Make sure that no one can be endangered by machines turning over by slipping or by moving machine parts.
3. When being transported on vehicles, precautions have to be taken that vibration plates do not slip or turn over.

### Maintenance checks

According to the conditions and frequency of use, vibratory plates have to be checked for safe operation at least once a year by skilled technicians, such as those found at WACKER-service depots and have to be repaired if necessary.

**Please also observe the corresponding rules and regulations valid in your country.**

## TECHNICAL DATA

	VPH 70	VPR 70	VPB 70	VPY 70
<b>Machine No.</b>	6907	6909	7007	7001
Forward speed m/min:	up to 28			
Surface compaction performance m <sup>2</sup> /h:	up to 770			
Gradeability %	up to 35			
Compaction depth mm:	up to 300			
<b>Operating weight</b> kg:	77	78	80	90
<b>Power transmission</b>	From engine via centrifugal clutch and V-belt onto exciter which transmits centrifugal forces directly onto baseplate			
<b>Exciter</b>				
Vibrations min <sup>-1</sup> (Hz):	7000(116.7)			
Centrifugal clutch kN:	19.8			
<b>Drive</b> (Air cooled single cylinder 4 stroke)	Petrol			Diesel
Piston displacement cm <sup>3</sup> :	163	183	126	199
Engine speed min <sup>-1</sup> :	3600			
Nominal output kW(Hp):	4.1 (5.5)	3.7 (5.0)	3.0 (4.0)	3.2 (4.2)
Fuel	Unleaded			Diesel
Fuel consumption l/h:	1.27	1	0.95	0.96
Tank capacity l:	3.6	3.8	3	2.5

The required sound specifications, called- for by the EC-Machine Regulations per Appendix 1, Paragraph 1.7.4.f, are

-sound pressure level at the operator's location  $L_{pA} = 89$  dB(A)

-sound power level  $L_{wA} = 102$  dB(A)

The sound values were determined according to ISO 3744 for the sound power level ( $L_{wA}$ ) and, alternatively, ISO 6081 for the sound pressure level ( $L_{pA}$ ) at the operator's location.

The weighted effective acceleration value, determined according to ISO 8662, Part 1, is  $18$  m/s<sup>2</sup>.

The sound and vibration measurements were carried out and obtained with the machine working on crushed gravel at nominal engine speed.

**Fields of applications**

Owing to the infinitely variable centrifugal force and advance speed of these machines it is possible to adapt optimally to the material to be compacted. They may therefore be used for the compaction of most types of soil, including semicohesive soils, in trenches as well as in surface compaction, plus compaction of bituminous mix and vibrating of interlocking paving blocks. When fitted with the water sprinkler system, it is suitable for hot asphalt.

**Dimensions**

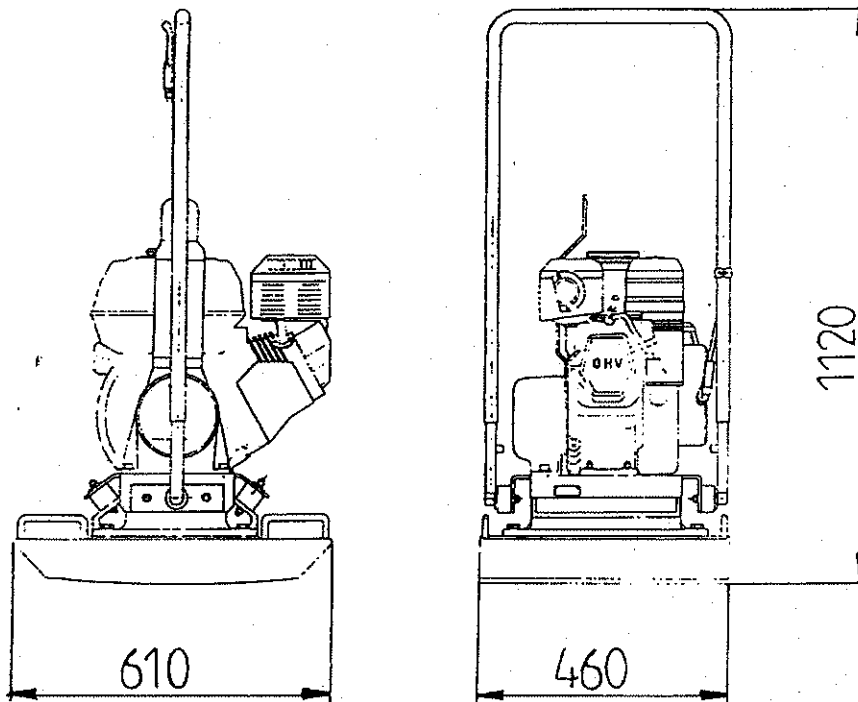

**Maximum admissible inclination**

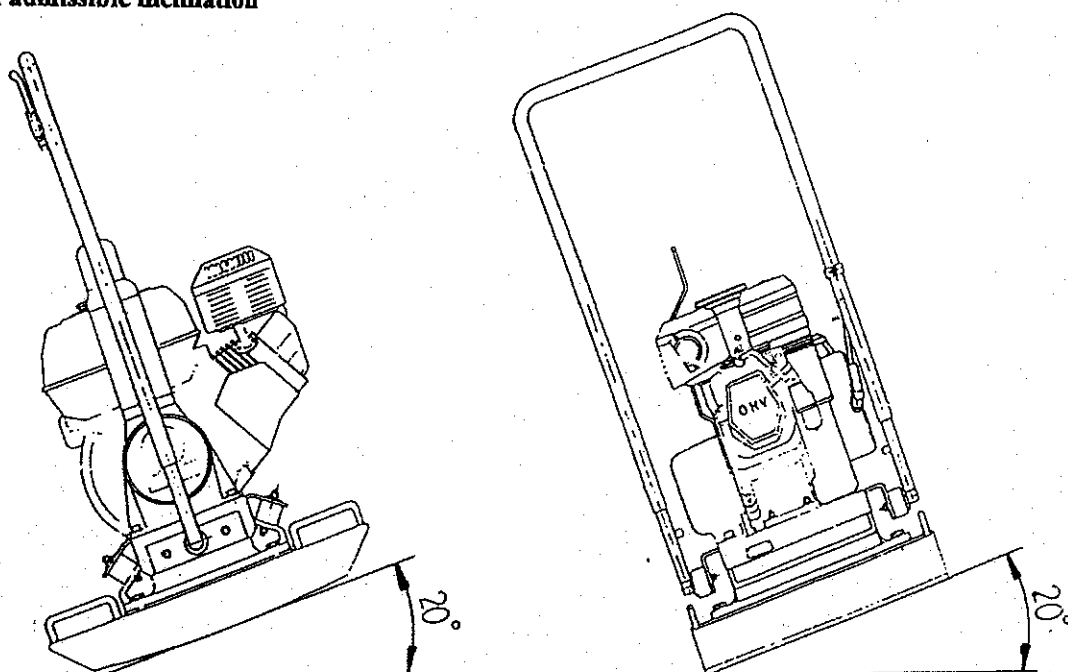



## Description of function

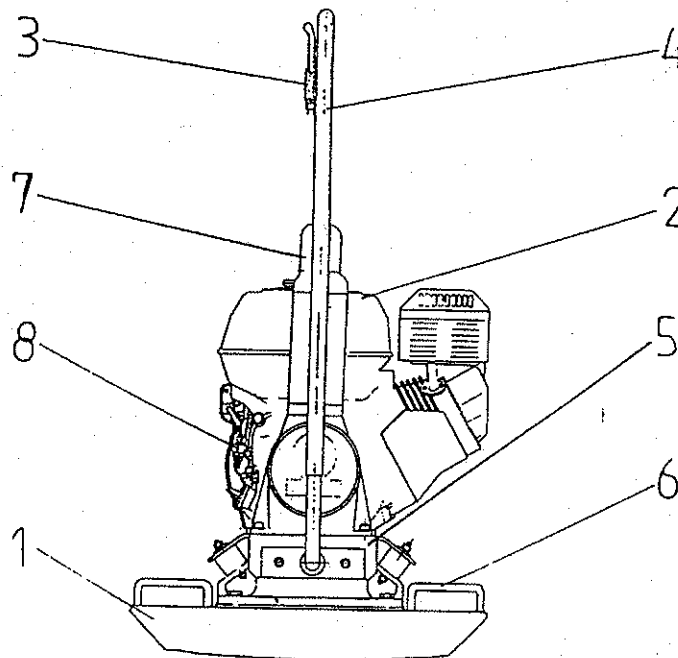

The compact design base plate (1) with centrally mounted, fully enclosed, exciter for an even spread of compactive impact over the whole base plate.

The engine (2) with recoil starter which is isolated from the vibration of the base plate (1) by 4 shock absorbing rubber dampers. With that and despite high compaction efficiency, the functionality of the drive engine (2) is maintained. The drive engine rpm's can be varied infinitely by mean of the throttle control lever (3) which is placed on the reversible handle (4).

The reversible handle (4), is fixed onto the engine console (5) therefore it is vibration isolated, for ease of operation and reduced operator fatigue.

The lifting handle (6) as well as the lifting bracket (7) is conveniently placed.

The oil alert system (8) stops engine automatically when oil lubrication falls below safe limits.

Drive is an air cooled unleaded/gasoline/diesel engine with recoil starter and dry air filter.

## TRANSPORT TO WORK SITE RECOMMENDATIONS ON COMPACTION

---

### Transport to work site

#### Prerequisites:

- Only use suitable lifting gear with a minimum load - bearing capacity of 200 kg to transport the vibration plate
- Always switch engine off before transport!
- Attach suitable tackle only to the central lifting point of the vibration plate.
- When transporting the vibration plate on the loading area of a transport vehicle always tie it down using the lugs.

☛ **ATTENTION!** Do not hitch up the equipment by the handle!

**Note:** Also observe the regulations in the chapter "Safety instructions".

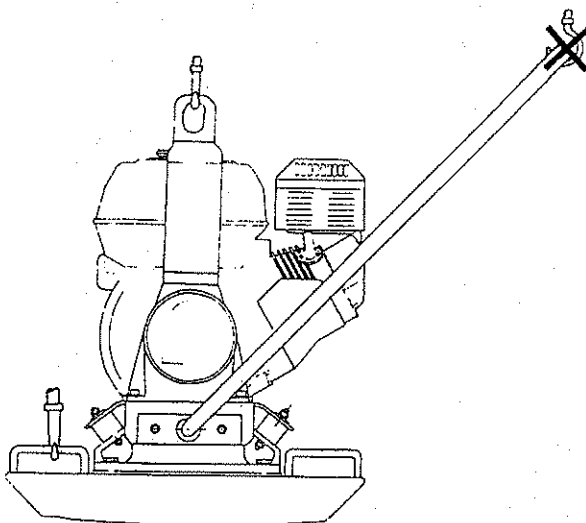

### Recommendations on compaction

#### Ground conditions

The max. compaction depth depends on several factors relating to the ground condition, such as moisture grain distribution etc., it is therefore not possible to specify exact values.

**Recommendation:** In each case determine the max. compaction depth with compaction tests and soil samples.

#### Compaction on slopes

The following points are to be observed when compacting on sloped surfaces (slopes, embankments):

- \* Only approach gradients from the bottom (a gradient which can be easily overcome upwards, can also be compacted downwards without any risk).
- \* The operator must never stand in the direction of descent (see chapter "Safety instructions")
- \* The max. gradient of 20° must not be exceeded.

☛ **ATTENTION!** Exceeding the gradient of 20° may lead to severe damage of the engine due to the lack of engine lubrication and thus lead to a breakdown of important engine components.

---

**GENERAL AND MOUNTING INSTRUCTIONS**

**GENERAL:**

**A. V-BELT ADJUSTMENT:**

1. Remove the belt guard.
2. Remove the engine mount and place washers on the shock mounts.
3. The V-belt has correct tension when you can press in the belt, for a distance equal to the thickness of the belt, approximately 12 mm.
4. Refit engine mount and belt guard. Tighten nuts and bolts.

**B. REGREASING OF EXCITER:**

1. Remove exciter.
2. Check and re-grease exciter bearings after every 500 hours of operation. Use Shell ALVANIA R 3 or equivalent.
3. If bearings are rough replace with new ones. As these bearings are special tolerance roller bearings they must be replaced with factory recommended types only.
4. Wash out bearings, pillow block and bearing cover in cleaning solvent. After drying, fill bearings fully and pillow block 3/4 full with Shell ALVANIA R 3.
5. Reassemble exciter.

**C. STORAGE INSTRUCTIONS:**

Engines to be stored for more than 30 days should be completely drained of fuel to prevent gum deposits forming on essential carburettor parts, fuel filter, fuel lines and tank

1. All fuel should be removed from the fuel tank. Run the engine until it stops from lack of fuel. The small amount of fuel remaining in the sump of the tank should then be removed by inverting the engine or absorbing with a clean dry cloth.
2. While engine is still warm, drain oil from crankcase. Refill with fresh oil.
3. Clean dirt and chaff from cylinder, cylinder head fins and blower housing.
4. Place cover over the engine.
5. Store the machine in a dry and dust free area.

## Engine oil

Check oil level with dip stick.

Place engine in horizontal position.

If oil level is too low, top up with HD brand quality oil SAE 15W 40 through oil feed opening.

## Oil change

Drain the oil while the engine is still warm to assure rapid and complete draining.

1. Remove the oil filter cap and the drain plug to drain the oil.
2. Install the drain plug, and tighten it securely.
3. Refill with the recommended oil and check oil level.
4. Install the oil filter cap.

Engine oil capacity: 0,6l (1,06 US qt, 1,78 Imp pt)

## Air filter service

A dirty air filter will restrict air flow to the carburettor. To prevent carburettor malfunction, service the air filter regularly. Service more frequently when operating the engine in extremely dusty areas.

**Warning:** Never use gasoline or low flash point solvents for cleaning the air cleaner element. A fire or explosion could be the result.

**Caution:** Never run the engine without the air cleaner. Rapid engine wear will result.

## Dual type air filter

1. Remove the wing nut and the air filter cover. Remove the elements and separate them. Carefully check both elements for holes or tears and replace if damaged.
2. Foam elements: Wash the element in a solution of household detergent and warm water, then rinse thoroughly, or wash in non-flammable or high flash point solvent. Allow the element to dry thoroughly. Soak the element in clean engine oil, and squeeze out the excess oil. The engine will smoke during initial start-up if too much oil is left in the foam.
3. Paper element: Tap the element lightly several times on a hard surface to remove excess dirt, or blow compressed air through the filter from the inside out. Never try to brush the dirt off; brushing will force dirt into the fibres. Replace the paper element if it is excessively dirty.

## Fuel tank

### Fuel strainer cup cleaning

Turn the fuel valve to Off. Remove the sediment cup and O-ring, and wash them in non-flammable or high flash point solvent. Dry them thoroughly, and reinstall securely. Turn the fuel valve on, and check for leaks.

**Maintenance schedule**

Check all external screw connections for a tight fit approx. 8 hours after first operation.		
Component	Maintenance	Maintenance interval
Air filter	Check for external damages and tight fit.	Daily
Fuel	Check filter insert - clean or replace if necessary.	
Drive engine	Check to see if fuel cap of tank fits tightly	
Exciter	replace if necessary.	
Other	Check oil level - top up if needed.	
Drive engine	Check tightness	25 hours
Drive engine	Check smooth movement of bowden cable	
Drive engine	First oil change. Engine oil capacity: 0.63 l. Use SAE 15 W 40 oil.	50 hours
Ignition	Oil change.	Weekly
V-belt	Clean spark plug, check spark plug air gap	
others	Correct gap 0.7mm - 0.8mm	
Fuel	Check belt tension - tighten if necessary.	
Shock mount	Grease external moving parts, such as transport device, wheel shaft, transport lock, etc.	
	Check passage of fuel through filter - replace if needed.	
	Check and replace if cracked.	

**Note:** Maintenance interval is based on the assumption of 8 hours operation per day.

### The engine does not run, or does so irregularly

- Cause:
- No fuel in the tank.
  - Fuel cock closed.
  - Not enough or too much lubricating oil in the engine.
  - Recoil starter pulled too slowly.
  - Air filter dirty.

- Remedy:
- Check fuel level in tank and refill.
  - Open fuel cock.
  - Check oil level and if necessary, correct.
  - Pull recoil starter hard and quickly.
  - Clean air filter.

### No vibration, even though engine is running

- Cause/Remedy:
- Check V-belt for wear and replace if necessary.
  - Check clutch wear.